

A large graphic of a magnifying glass with a blue handle and frame, and a yellow lens. The lens contains the document title.

DATA SHEET

**ES-2835-022V-L1-RXXX
(RED)**

CONTENTS

1. Introduction and features
2. Applications
3. Package dimensions
4. Absolute maximum ratings
5. Characteristic and curves
6. Reflow solder characteristics
7. Packaging specification

ES-2835-022V-L1-RXXX Datasheet



Red Color

This 2835 LED Light Source is a high performance energy efficient device which can handle high thermal and high driving current. The small package outline and high intensity make it an ideal choice for Color LED panel light, LED bulb light, LED tube light, backlighting and etc.

These Low Power Color LED is available in the various colors like Red, Amber, Pink, Green, Blue. This part has a foot print that is compatible to most of the same size LED in the market today.



FEATURES

- Available in various colors like Red, Amber, Pink, Green & Blue.
- Compatible industry standard 2835 pkg
- Low voltage operation, Instant light
- Small package with high efficiency
- Long operation life
- Lead free product
- RoHS compliant

APPLICATIONS

- Flat panel light
- Backlighting
- LED tube light
- LED bulb light
- Decorative and landscape lighting
- Signage and channel letter
- Reading lamp
- Decorating and entertainment lighting
- Architectural lighting

PACKAGE DIMENSIONS

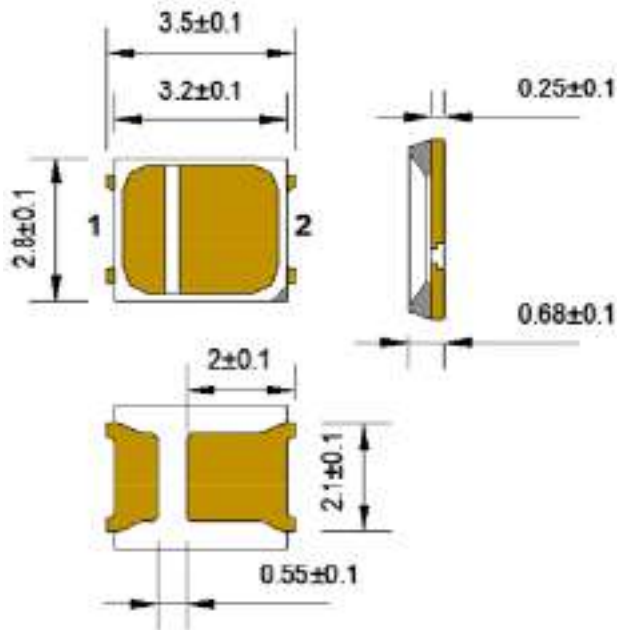

Recommended Solder Pad Design

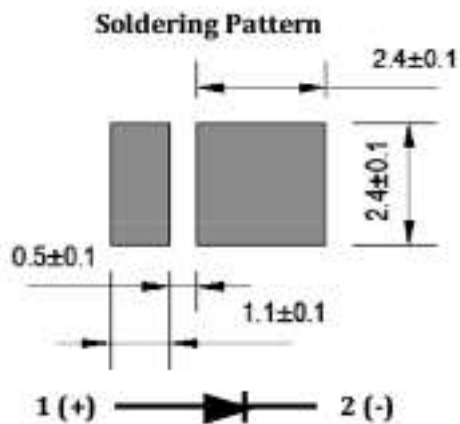

Notes:

1. All dimensions in millimeters.
2. Thickness tolerance of copper plate is ± 0.02 mm.
3. Thickness tolerance of product is ± 0.05 mm.
4. Tolerance is ± 0.1 mm unless otherwise noted.

ABSOLUTE MAXIMUM RATINGS (TA=25 ±5°C)

Item	Symbol	Absolute Maximum Rating	Unit
Forward current	I _F	70	mA
Pulse Forward Current	I _{FP}	100	mA
Thermal Resistance (Junction / Soldering point)	Rth J-S	50	°C/W
Power Dissipation	Pd	150	mW
Operating Temperature	T _{opr}	-30~80	°C
Storage Temperature	T _{stg}	-40~85	°C
Soldering Temperature	T _{slid}	Reflow Soldering:260°C Hand Soldering:350°C	For 10 sec For 30 sec

Note: Test Temperature = 25°C

CHARACTERISTICS (Tj=25°C)

Item	Symbol	Condition	Min	Typ	Max	Unit
Forward Voltage	V _F	I _F =60mA	1.8	--	2.6	V
Viewing Angle	2θ _{1/2}	I _F =60mA	--	120	--	deg.
Luminous Intensity	I _v	I _F =60mA	1750	--	3500	mcd
Junction temperature	T _j	I _F =60mA	--	--	115	°C
Reverse Current	I _r	V _r =5V			10	uA
Antistatic ability	ESD			2000		V
Dominate Wavelength	Wd	I _F =60mA	615	--	625	nm

Notes:

1. Luminous flux is measured with an accuracy of ± 10%.
2. Chromaticity coordinate bins are measured with an accuracy of ± 0.01.
3. CRI is measured with an accuracy of ± 2.
4. Some color and CRI bins may have limited availability, please contact us before ordering.
5. All measurements were made under the standardized environment of Everstar

TYPICAL OPTICAL-ELECTRICAL CHARACTERISTICS CURVES

Forward Current VS Forward Voltage

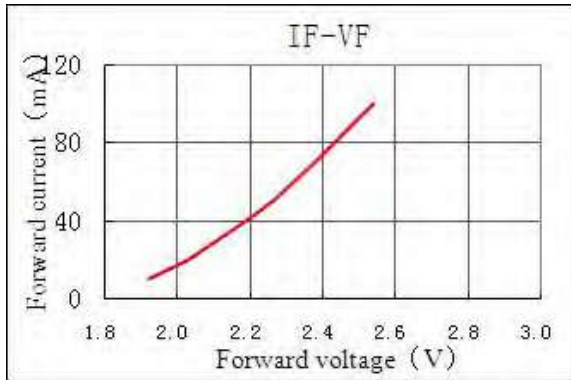

Relative Flux VS Forward Current

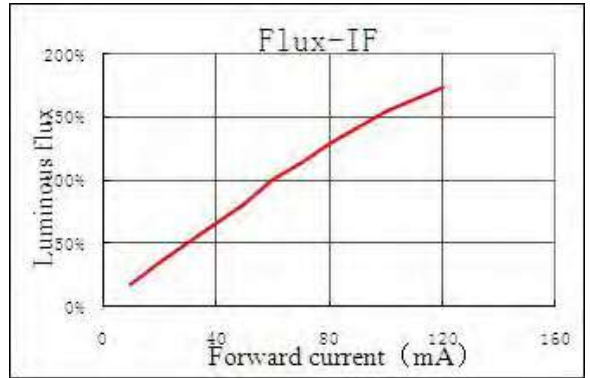

Relative Flux VS Ambient Temperature

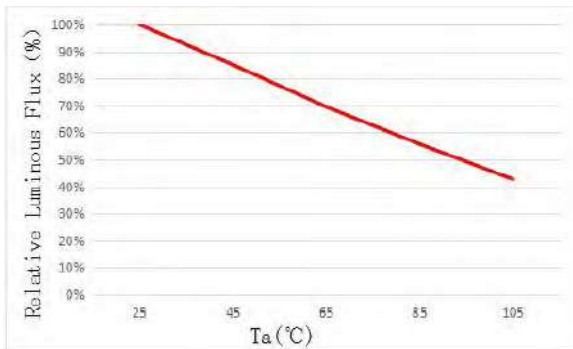

Forward Current VS Ambient Temperature

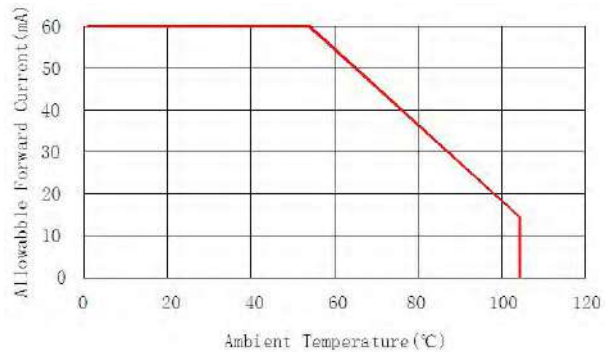

Spectrum Distribution

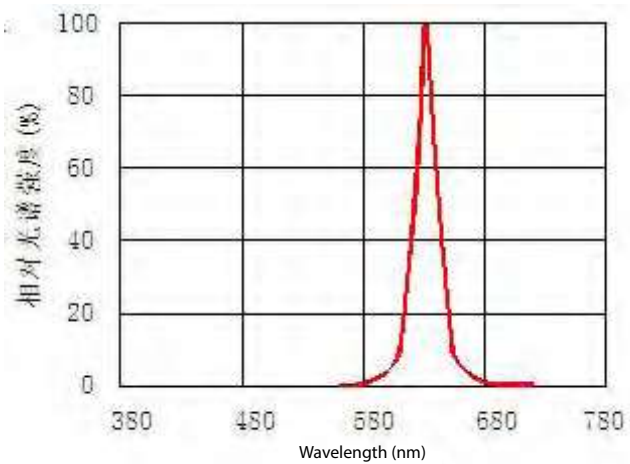

Typical Spectral Distribution

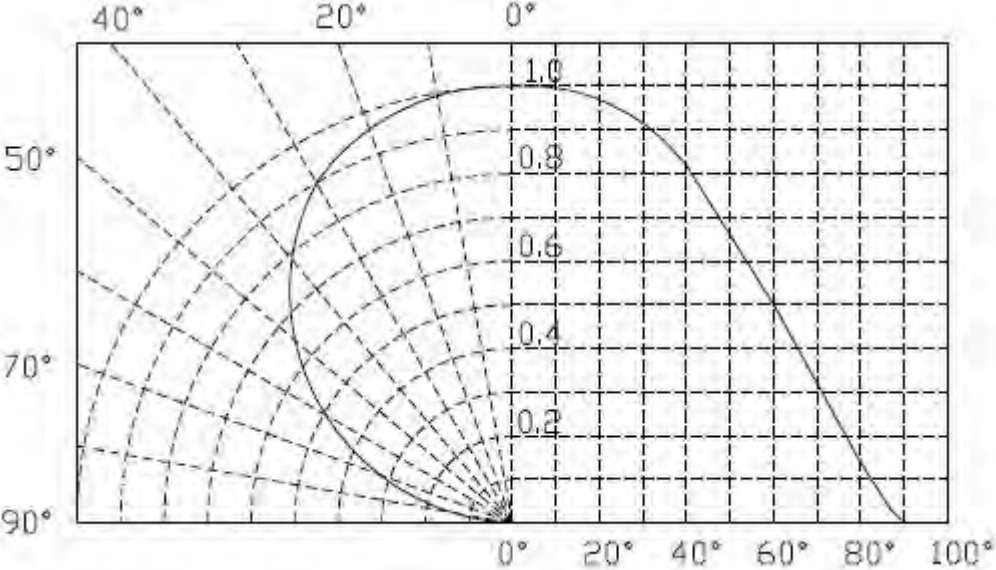

REFLOW SOLDERING CHARACTERISTICS

Preheating : 140°C~160°C±5°C,within 2 minutes.
 Operation heating : 260°C(Max.) within 10 seconds.(Max)
 Gradual Cooling (Avoid quenching).

Lead solder		Lead-free solder	
Pre-heat	120-150°C	Pre-heat	150-200°C
Pre-heat time	120 sec.Max.	Pre-heat time	120 sec.Max.
Peak Temperature	240°C Max.	Peak Temperature	260°C Max.
Soldering time condition	10 sec.Max.	Soldering time condition	10 sec.Max.

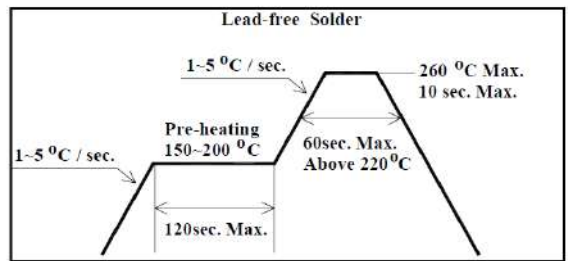
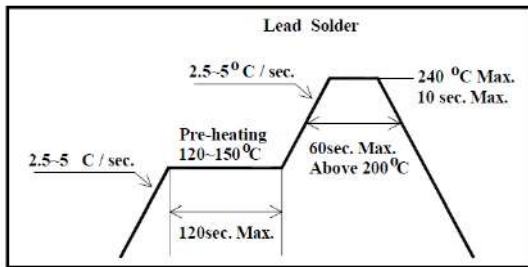

Notes:

The encapsulated material of the LEDs is silicone . Therefore the LEDs have a soft surface on the top of package. The pressure to the top surface will be influence to the reliability of the LEDs. Precautions should be taken to avoid the strong pressure on the encapsulated part. So when using the picking up nozzle, the pressure on the silicone resin should be proper.

TAPE AND REEL

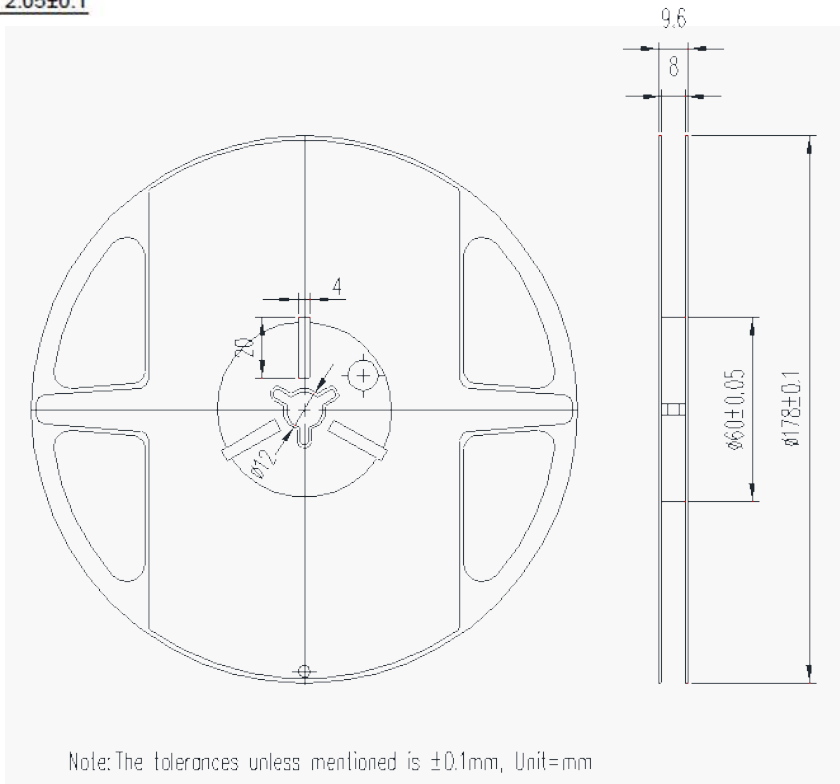
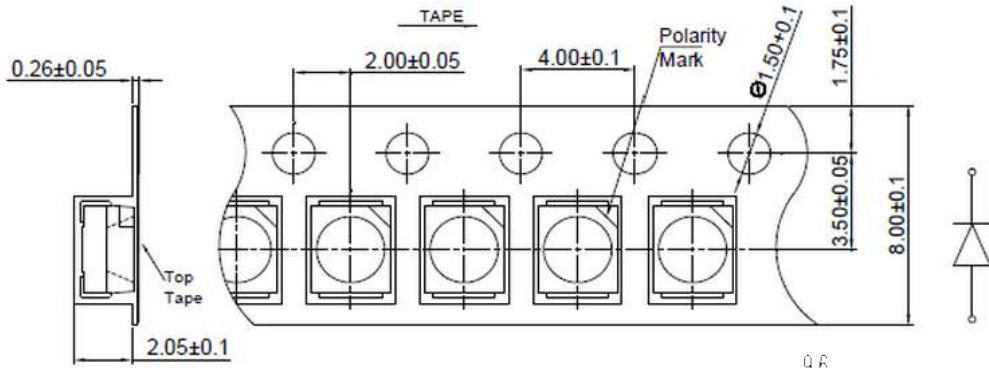

Notes:

- (1) Quantity : 4,000pcs/Reel
- (2) Cumulative Tolerance : Cumulative Tolerance/10 pitches to be ± 0.2 mm
- (3) Adhesion Strength of Cover Tape : Adhesion strength to be 0.1-0.7N when the cover tape is turned off from the carrier tape at the angle of 10° to the carrier tape
- (4) Package : P/N, Manufacturing data Code No. and quantity to be indicated on a damp proof Package.

PACKAGING

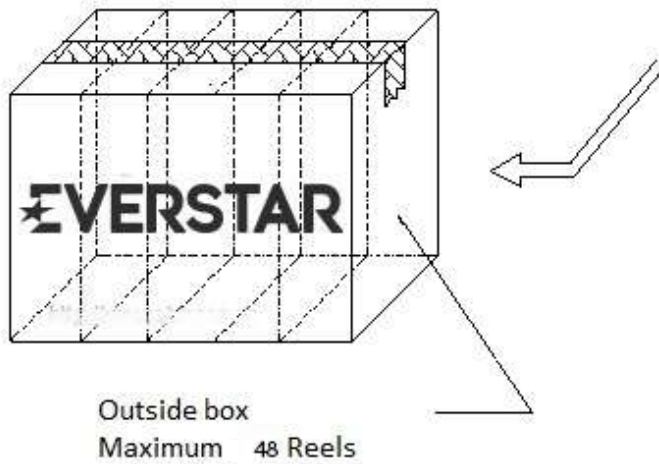
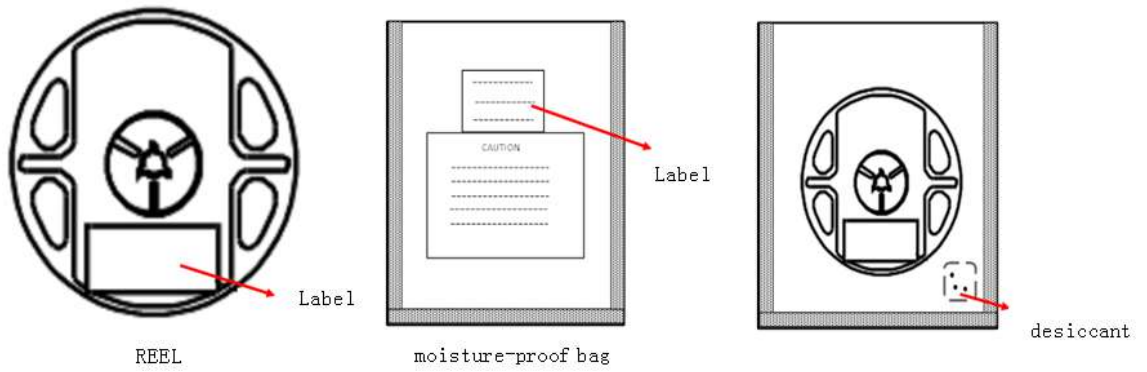

Test items and results of reliability

Test Items	Test Conditions	Duration/Cycle	Quantity	Ac/Re
Temperature	-40°C 30min ▲▼ 25°C (2min) 100°C 30min	100 times	22PCS	0/1
Thermal Shock	-40°C 30min ▲▼ 5 sec 110°C 30min	100 times	100PCS	0/1
High Temperature Storage	Ta=100°C	1000 hours	22PCS	0/1
Humidity Heat Storage	Ta=85°C RH=85%	1000 hours	22PCS	0/1
Low Temperature Storage	Ta=-40°C	1000 hours	22PCS	0/1
Room Temperature Storage	Ta=25°C If=60mA	1000 hours	22PCS	0/1

PRECAUTION FOR USE

1. This device should not be used in any type of fluid such as water, oil, organic solvent, etc. When washing is required, IPA should be used.
2. When the LEDs are illuminating, operating current should be decided after considering the ambient maximum temperature.
3. LEDs must be stored to maintain a clean atmosphere. If the LEDs are stored for 3 months or more after being shipped from EVERSTAR, a sealed container with a nitrogen atmosphere should be used for storage.
4. The LEDs must be used within seven days after opening the moisture proof packing. Repack unused Products with anti-moisture packing, fold to close any opening and then store in a dry place.
5. The appearance and specifications of the product may be modified for improvement without notice.
6. This LED is sensitive to the static electricity and surge. It is recommended to use a wrist Band or anti-electrostatic glove when handling the LEDs.
7. On manual soldering, a solder tip must be needed as grounded for usage. If over voltage which exceeds the absolute maximum rating is applied to LEDs, it will cause damage LEDs and result in destruction. Damaged LEDs will show some unusual characteristics such as leak current increase remarkably, turn-on voltage becomes lower and the LEDs get unlighted at low current.